

Rules of the Game

- You have 50 minutes for this exam. The exam will end promptly at 11:55pm.
- The exam is closed notes / closed book. You are allowed one handwritten sheet of notes
- Absolutely no cheating

Each question is worth 3 points. If you do not write your answer in the line provided, you will not get credit for your answer. We will not grade anything else but the objective answers you provide below. In all cases, you should choose the most correct answer for your solution.

You get one point for putting your name correctly on the top of this paper.

Column for Answers (letters only)	Column for Answers (letters only)	Column for Answers (letters only)
1.	2.	3.
4.	5.	6.
7.	8.	9.
10.	11.	12.
13.	14.	15.
16.	17.	18.
19.	20.	21.
22.	23.	24.
25.	26.	27.
28.	29.	30.
31.	32.	33.

Questions 1 through 4 (Q1 - Q4) refer to filling in the table below for a silicon substrate typical CMOS device. Choose the best answer.

(a) $I = \frac{K}{2} (V_{gs} - V_T)^2 (1 + \lambda V_{ds})$

(b) $I = I_{th} \exp(\kappa(V_{gs} - V_{T0}) + \sigma V_d)$

(c) $I = K \left((V_{gs} - V_T) V_{ds} - \frac{1}{2} V_{ds}^2 \right)$

(d) $I = I_{th} \left(\exp(\kappa(V_g - V_{T0}) - V_s - \sigma V_d) - \exp(\kappa(V_g - V_{T0}) - V_d - \sigma V_s) \right)$

(e) $I = \frac{K}{2\kappa} (\kappa(V_g - V_{T0}) - V_s)^2 \left(1 + \frac{V_d}{V_A} \right)$

(f) $I = I_{th} \exp(\kappa(V_g - V_{T0}) - V_s + \sigma V_d)$

(g) $I = \frac{K}{2\kappa} \left((\kappa(V_g - V_{T0}) - V_s)^2 - (\kappa(V_g - V_{T0}) - V_d)^2 \right)$

(h) $I = I_{th} \exp(\kappa(V_g - V_{T0}) - V_s - \sigma V_d)$

	Subthreshold	Above threshold
Ohmic	Q1	Q2
Saturation	Q3	Q4

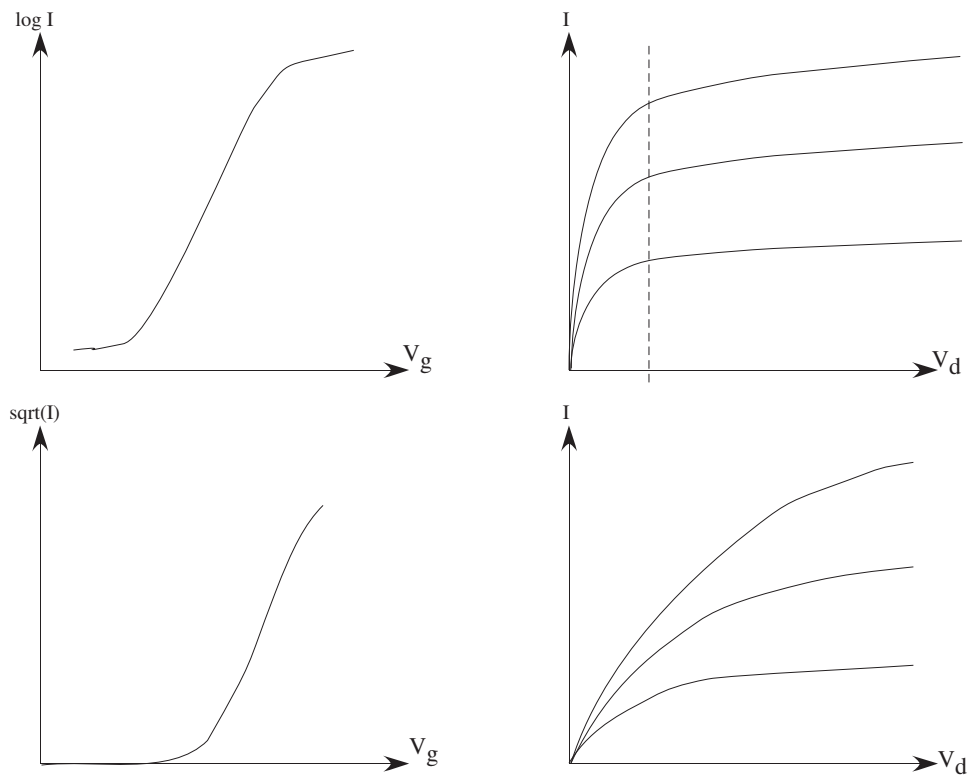

Fig. 1. 4 Voltage – current plots for questions 5 through 8. The plots on the first row are (a) and (b), respectively, and the plots on the second row are (c) and (d).

Questions Q5 through Q8 refer to filling in the table below based on the labeled I-V measurements from a MOSFET device from Fig 1. Choose the best answer.

	Subthreshold	Above threshold
Ohmic	Q5	Q6
Saturation	Q7	Q8

Questions Q9 through Q20 refer to filling in the table below for small-signal parameters for a MOSFET device based on its bias current, I_{ref} . Select from the potential answers below and make the closest, *reduced, and best* possible choice. Of course, some values could be used multiple times if appropriate.

(a) 1 (h) $\sqrt{2KI_{ref}}$ (n) $\sqrt{\frac{2K}{\kappa}}V_A$

(b) κ (i) $\sqrt{2\kappa KI_{ref}}$ (o) $\frac{\sqrt{2K}}{V_A}$

(c) $\frac{1}{\kappa}$ (j) $\kappa\sqrt{2KI_{ref}}$ (p) $\sqrt{\frac{2\kappa K}{I_{ref}}}V_A$

(d) σ (k) $\frac{U_T}{\sigma I_{ref}}$ (q) $\frac{\sqrt{\frac{2K}{I_{ref}}}}{V_A}$

(e) $\frac{1}{\sigma}$ (l) $\sqrt{\frac{2KI_{ref}}{\kappa}}$ (r) $\sqrt{\frac{2K}{\kappa I_{ref}}}V_A$

(f) $\frac{\kappa}{\sigma}$ (m) $\frac{V_A}{I_{ref}}$ (s) $\frac{\kappa I_{ref}}{U_T}$

(g) $\frac{I_{ref}}{U_T}$

Another table: Small signal model equations, as well as products

	g_m	g_s	r_o	g_m / g_s	$g_m r_o$	$g_s r_o$
Subthreshold	Q9	Q10	Q11	Q12	Q13	Q14
Above Threshold	Q15	Q16	Q17	Q18	Q19	Q20

Questions Q21 through Q24 are true or false. Answer (a) for True, and (b) for False.

Q21: Transconductance is defined as

$$\frac{\partial I_s}{\partial V_s}$$

Q22: κ is the resulting gain from the capacitive coupling ratio from the gate terminal to the surface potential for a MOS capacitor in a MOSFET device whether the MOS capacitor is in depletion or inversion.

Q23: I_{th} is always the current measured with a MOSFET gate voltage at the threshold voltage.

Q24: σ is the coupling between the drain terminal and the gate terminal through the effect of charge in the resulting MOSFET depletion region.

Q25: We use V_{T0} to designate a threshold voltage that changes with source voltage.

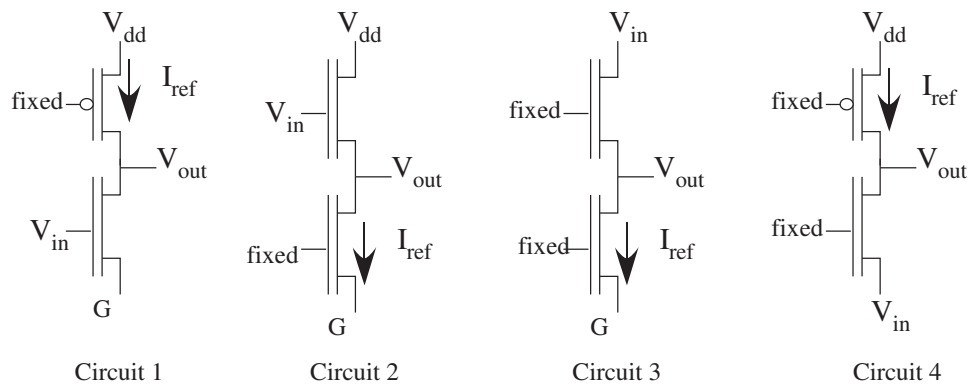

Fig. 2. Four fundamental two-transistor circuits.

The following questions correspond to the resulting basic circuit diagrams (Fig. ??) with the designated input (V_{in}) and output (V_{out}) voltages. Assume $\sigma_n = 0.002$, $\sigma_p = 0.003$, $\kappa_n = \kappa_p = 0.75$. Assume all transistors are operating with a sub threshold bias current of 25nA. Choose the closest values.

Values for gain: (a) 0.002 (b) 0.003 (c) 0.04 (d) 0.1 (e) 0.75 (f) 1
 (g) 1.33 (h) 20 (i) 100 (j) 150 (k) 200 (l) 1000

Values for Output Resistance: (a) $1M\omega$ (b) $2M\omega$ (c) $5M\omega$ (d) $10M\omega$ (e) $20M\omega$
 (f) $50M\omega$ (g) $100M\omega$ (h) $200M\omega$ (i) $500M\omega$ (j) $1000M\omega$

	Circuit 1	Circuit 2	Circuit 3	Circuit 4
Gain	Q26	Q27	Q28	Q29
Output Resistance (R_{out})	Q30	Q31	Q32	Q33

Answers to the Exam:

Column for Answers (letters only)	Column for Answers (letters only)	Column for Answers (letters only)
1. d	2. g	3. f
4. e	5. b	6. d
7. a	8. c	9. s
10. g	11. k	12. b
13. f	14. e	15. i
16. l	17. m	18. b
19. p	20. r	21. b
22. a	23. b	24. a
25. b	26. h	27. e
28. a	29. j	30. h
31. a	32. a	33. h